



bajadesigns[®]
THE SCIENTISTS OF LIGHTING

2024-On Toyota Tacoma TRD Pro Replacement Light Kit (44-8253, 44-8261)



Note: Trimming required on the inside of the OEM grill.

2950 Norman Strasse San Marcos, CA 92069

Phone 760-560-2252 X3 • Fax 760-560-0383

info@bajadesigns.com • www.bajadesigns.com



baja designs[®]
THE SCIENTISTS OF LIGHTING

LIMITED LIFETIME WARRANTY

Baja Designs proudly offers a LIFETIME WARRANTY against manufacturer's defect on all the products that we manufacture.

These are comprehensive warranties; other than the exclusions below – you're covered. If your LED or HID bulb burns out, you're covered. Additionally, cutting off our connector or changing your lenses does not automatically void your warranty.

Exclusions:

Installation errors, abuse, misuse, or crash damage. You must be the original owner of the product and can supply proof of purchase.

Baja Designs manufactures its own products as well as resells products manufactured by others. Baja Designs makes no express or implied warranties on products not manufactured by Baja Designs including without limitation any warranties or merchantability and fitness for a purpose. We will, however, pass on all warranties made by the manufacturer, who has sole responsibility for performing such warranties.

Baja Designs will pay the freight if your product is less than 90 days old, otherwise defective products must be returned to Baja Designs, Inc., freight prepaid. At our option, we will repair or replace items in question and return them at no charge. If the identical product is no longer available, we will replace it with a similar product of equal value. Baja Designs Inc. will not be responsible for any indirect or consequential damages in connection with defective merchandise.

Items purchased through a Baja Designs authorized dealer must be returned through the dealer. Only available on LED auxiliary lights and product must be in sellable condition at MSRP. Product that has been damaged in any way after the original purchase date will be excluded from this guarantee.

Indemnification:

Buyer hereby acknowledges off-roading, racing and driving at night are dangerous activities and that the products and/or supplies purchased from Baja Designs are used in an inherently dangerous activity that may endanger life and limb; and in no event shall the seller, or seller's heirs and assigns, be held liable for consequential damages, nor shall seller's liability on any claim for damages arising out of or connected with the sale, delivery, or use of purchased products and/or supplies exceed the purchase price of the products and/or supplies.



Buyer is responsible for ensuring that it uses the products (and its vehicle) in accordance with all applicable laws, regulations, guidelines, and standards of care. Buyer acknowledges that some products may only be used when off-roading, and Buyer will comply with all vehicle and road safety guidelines. Buyer is solely responsible for (and will indemnify and hold Bestop harmless for) any claims, losses, damages, fines, fees, costs, or other amounts arising out of Buyer's non-compliance with these provisions.

****For a color copy of instructions, visit your vehicle specific application on BajaDesigns.com ****

Required Tool(s):

- Sockets: 10mm, 13mm, 7/16"
- Wrenches: 10mm, 13mm, 7/16"
- Misc: 4mm Hex tool, Phillips screwdriver, Dremel, masking tape, trim tools, diagonal cutters

Parts List:

 <p>(44-9445) (Qty:1) Toyota Tacoma (24-On), Bezel Bracket</p>	 <p>(44-9446) (Qty: 1) Toyota Tacoma (24-On), Grill Mounting Bracket</p>	 <p>(44-9447) (Qty: 2) Toyota Tacoma (24-On), S8 Mounting Bracket</p>	 <p>(20-1028) (Qty: 6) M6X1X20 Hex Bolt Black SS</p>
 <p>(20-1027) (Qty: 12) M6 Washer Black SS</p>	 <p>(20-1690) (Qty: 6) Hardware, M6 Nylock Nut 18-8 SS</p>	 <p>(65-0215) (Qty: 2) Parts bag, SQ/S2 Single, For Kits</p>	 <p>(Qty: 1) S8, 10" Driving/Combo LED Light Bar</p>
 <p>(64-0177) (Qty: 1) Wiring Harness, S8 Backlight Add-On</p>	 <p>(64-0115) (Qty: 1) Wiring Harness, OnX6+/S8 (10"-30") Off/On Harness</p>	 <p>(64-0117) (Qty: 1) Wiring Harness, SQ/S2 Off/On Wire Harness-2 Lights max 150 watts</p>	 <p>(48-9005) (Qty: 2) S2 Pro, Wide Cornering LED, For Kits</p>

To begin, make sure the vehicle is in park, on level ground and the parking brake is engaged.

Step 1: Vehicle Prep

Disconnect the negative battery terminal on the vehicle battery using a 10mm socket.



Step 2: Prepare S2s

Use a 4mm Hex tool and the 4X 6mm Button head bolts to install the mounting brackets to the two provided S2 Pros. Install the brackets in the orientation shown below. Make sure the 3/8 bolts and washers are already on the U bracket.

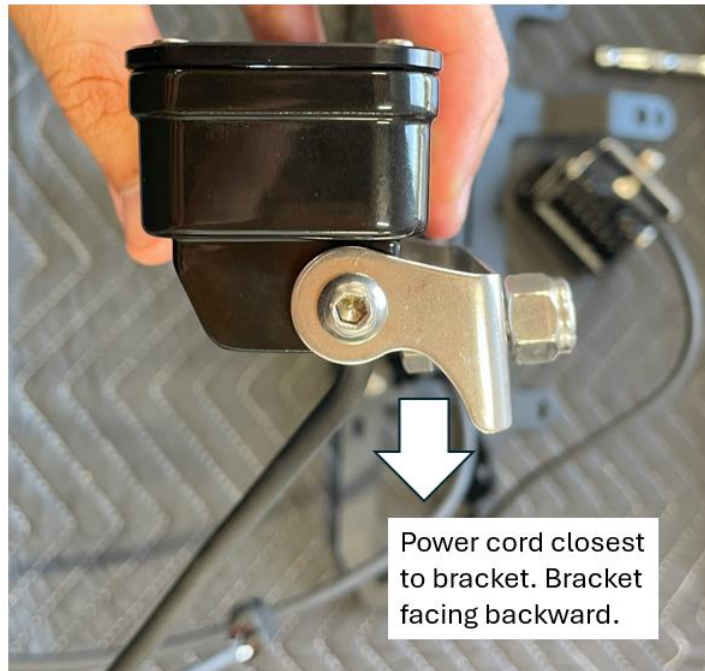

Step 3: Bracket Prep

Use a 10mm wrench and socket to install the two small S8 brackets onto the larger bracket using the black M6 bolts, black washers and nuts. Install them such that the two legs are facing inward towards the center (See photo below). **Leave loose for now. Make sure the black bolt heads are on the side the light is facing.**

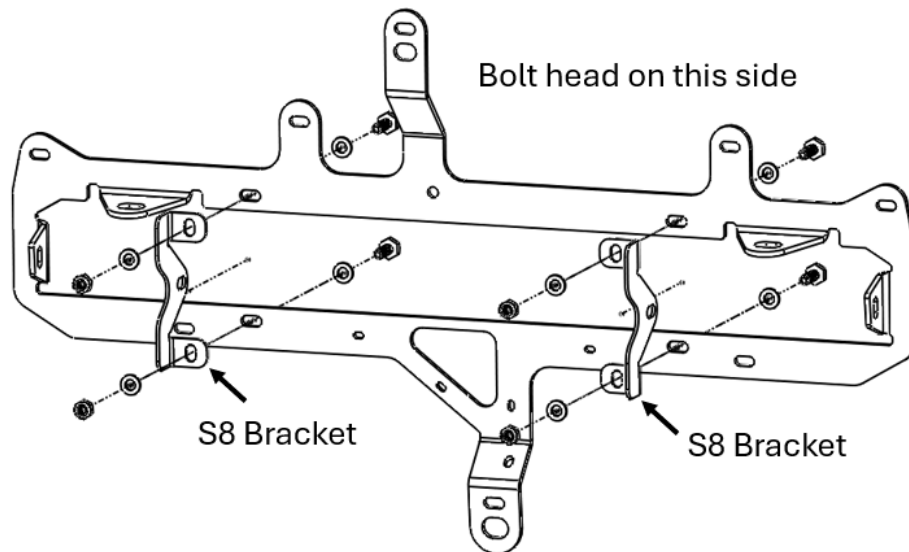

Pre-production parts shown. Actual parts may vary.

Step 4: Install 10" S8

Use a 7/16" socket and ratchet to install your S8 light bar with the 2X M6 Hex bolts and M6 washers provided with your light. **Leave loose for now.**



Step 5: Install 2X S2's

Using a 9/16" wrench & socket install the two S2s with the 3/8" bolts, washers, and nuts provided. **Leave loose for now.**



Step 6: Install the bezel piece

Slide the bezel piece over the front of the lights until the mounts line up with the holes on the main bracket. **Align the notched end of the brackets as seen in the photo below.** Adjust the lights so they are parallel to the bezel and straight. This is **crucial** as any further adjustments will be difficult.

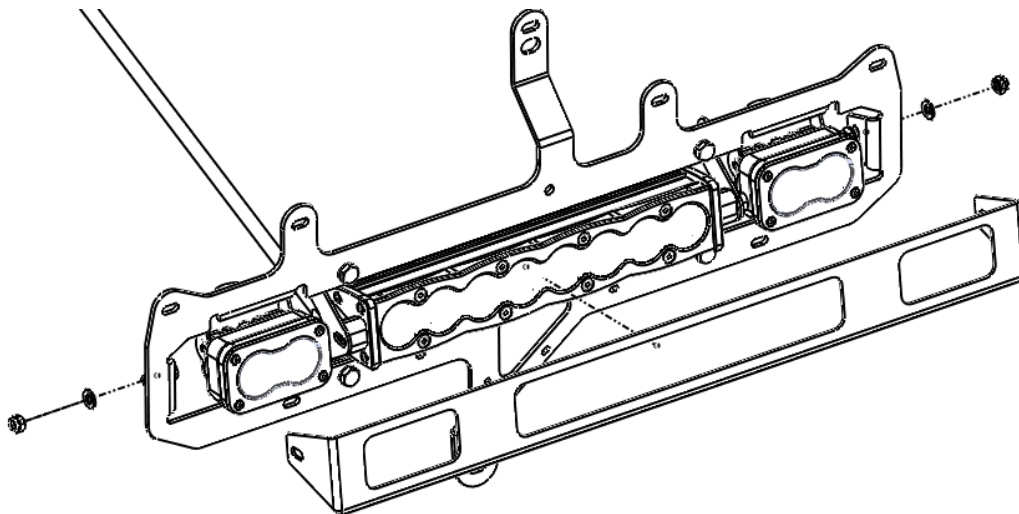



Step 7: Loosen the front fenders

Remove the 3 hex head fasteners on the inside of the fender using a 10mm socket (The third fastener is towards the top of the fender). Some fenders may have two additional plastic fasteners that will need to be removed by prying the head up. Firmly pull the fender corner directly away from the vehicle until you hear the clips disengage.

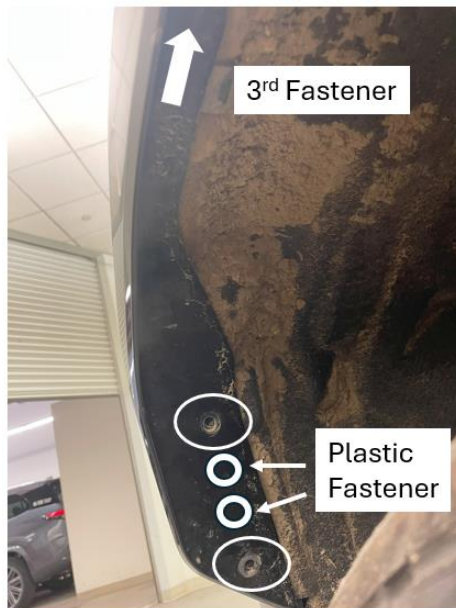

Step 8: Release the front fascia clips

Pull the corner of the front fascia (that was beneath the front fender) directly outward to free the clips. Pry between the clips to release them using a trim removal tool.



Step 9: Remove fasteners underneath the front fascia

Use a 10mm socket to remove the two fasteners in each corner along the bottom edge of the front fascia. Remove the two bolts accessible from the gap between the fascia and the skid plate.



Step 10: Remove the air intake

Remove the air intake by pushing the 4 clips circled below until they release and pulling them out. Completely remove the air intake and store it somewhere safe.



Step 11: Remove under the hood fascia fasteners

Use a 10mm socket to remove the 3X bolts at the locations circled below. Remove the two plastic fasteners (near the hood hinge) by pushing the center and pulling them out.



Step 12: Disconnect all connectors going to the front fascia/grill

Disconnect the 3 connectors found near the passenger side headlight/beneath the intake. Disconnect the two connectors found near the driver side bolt pictured above. Tuck them away to avoid pinching during reinstall. **Some vehicles may have less connectors.**

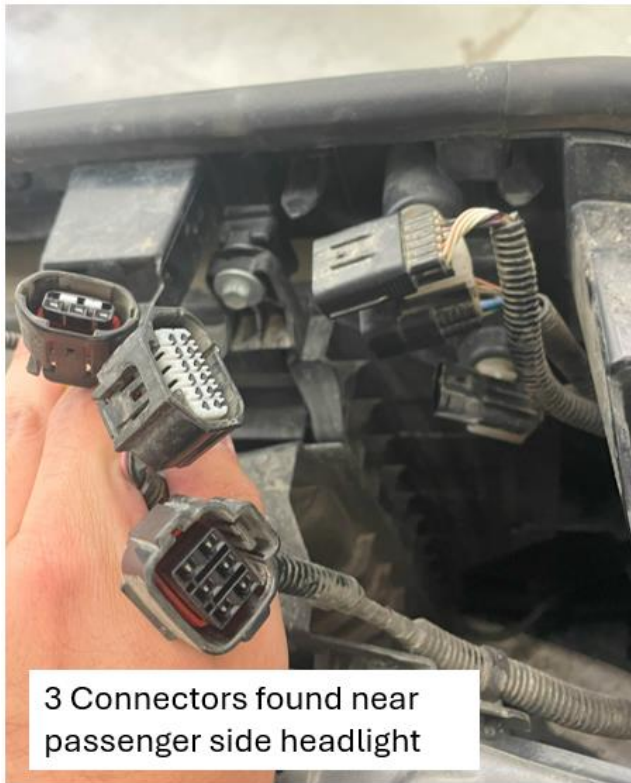

3 Connectors found near passenger side headlight



2 Connectors found near driver side bolt

Step 13: Remove the front fascia

Tape the bottom edge of the headlight to avoid scratches

With an assistant, Pull the front grill/fascia straight off the vehicle. Make sure to clear the locating nub on each mount from step 11.



Step 14: Remove the shutter system

Using a 10mm remove the 6 bolts holding the shutter system in place. Remove the shutter system and place it in a safe location.



Step 15: Remove the OEM light bar

Use a Phillips screwdriver to remove the 9X screws holding the light bar in place. Disconnect the connector from the light bar and remove the light bar.

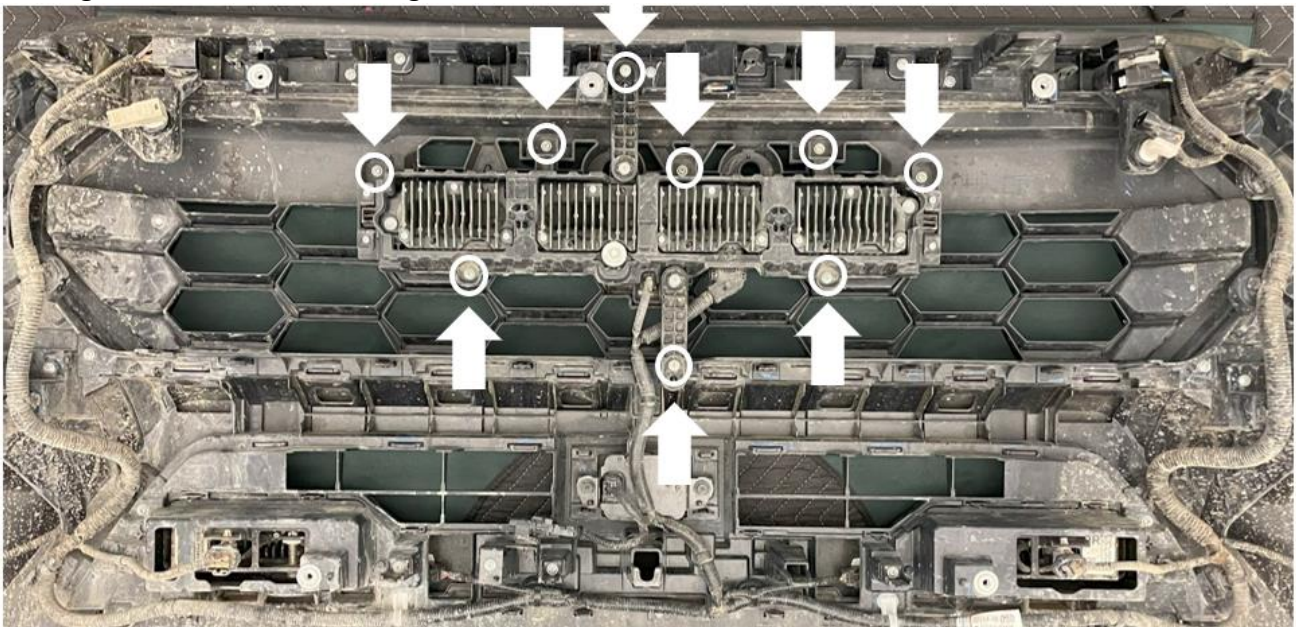

Step 16: Disconnect the camera

Disconnect the electrical connector leading to the front camera.

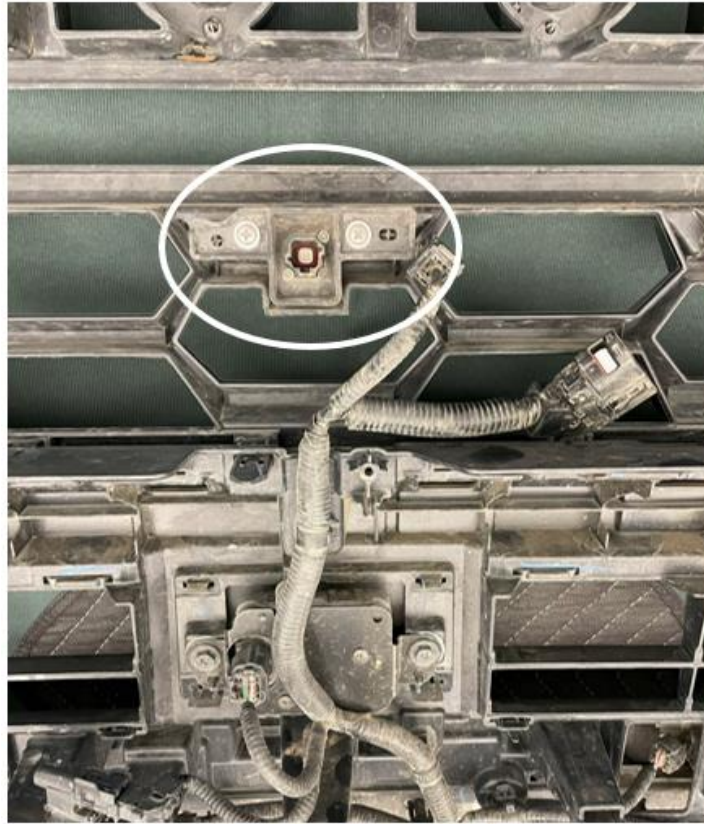

Step 17: Trim away height on mounting locations

Using a Dremel grind away the height of the two pictured OEM mounting locations. Trim them to the same height as the other mounting locations. **Roughly** 5mm from the top of the square base (A).

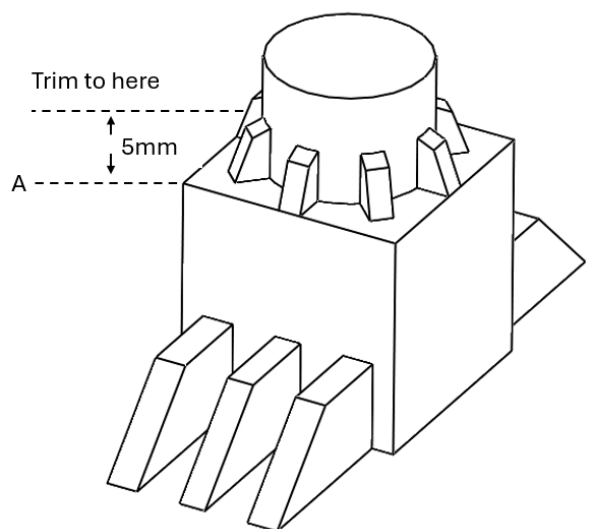

Step 18: Install the light bar assembly

Use a Phillips screwdriver and 8 of the screws removed in step 15 to install the light bar as seen in the photo below. Route the power cables down past the lowest mounting hole. Use the provided ziptie holes to route your cable **BEHIND** the mounting bracket to ensure wires are not visible from the front.

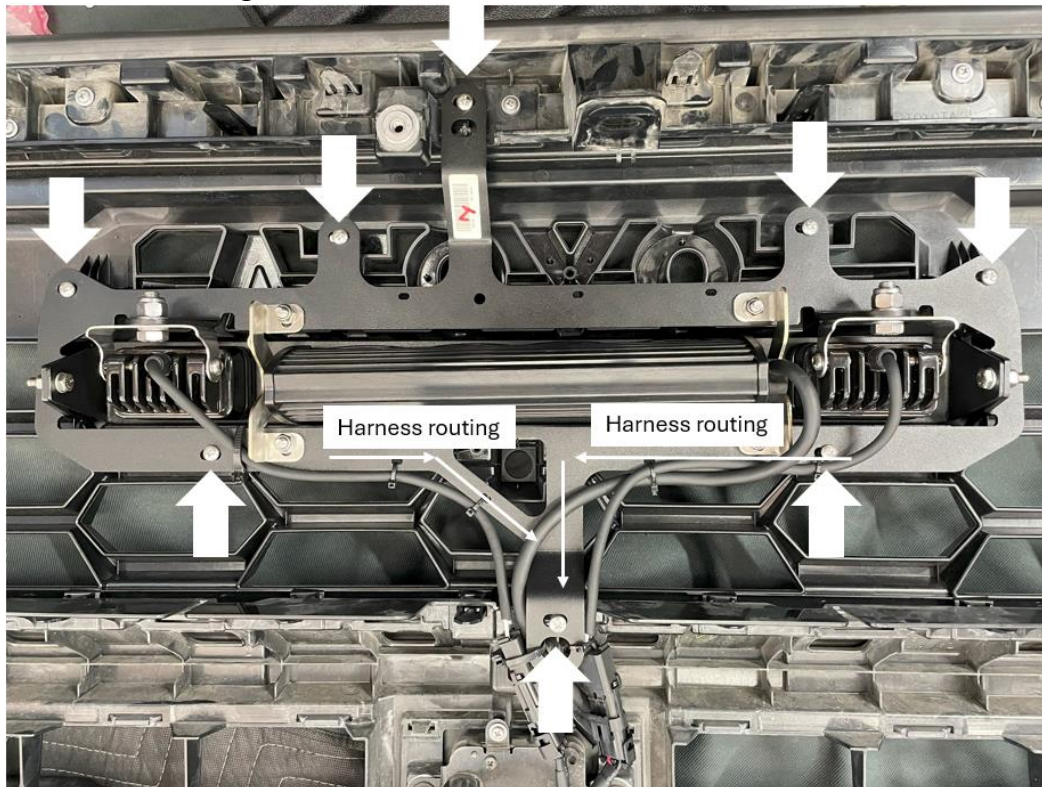

Step 19: Reconnect the camera

Reconnect the connector from step 16 through the provided cutout.

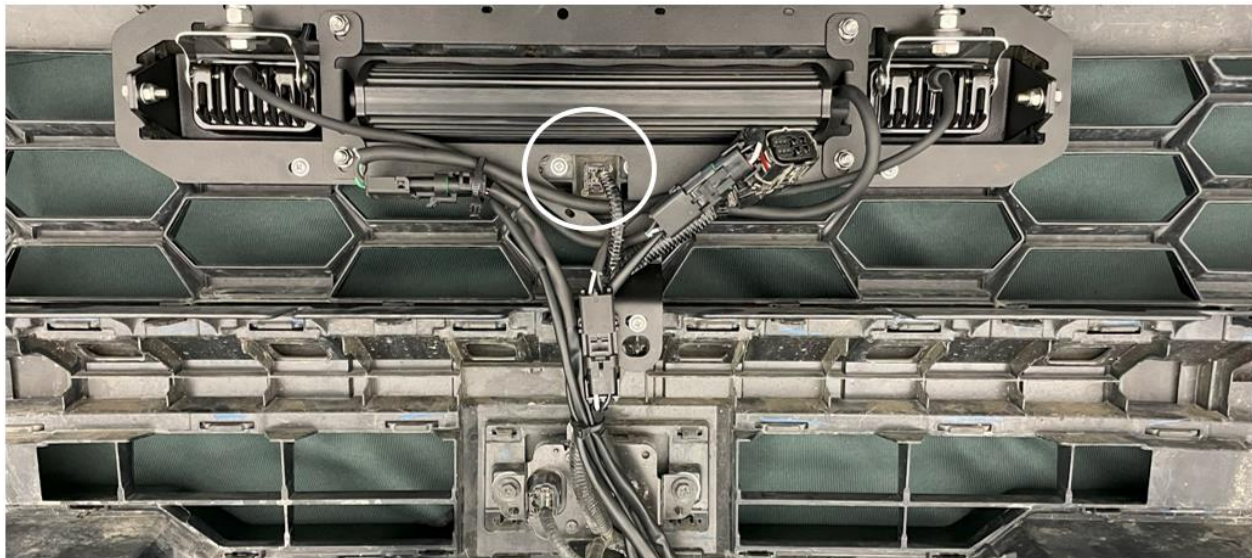

Step 20: Harness clean up

Tie away all loose wires and ensure the harness bundle is sitting tight against the bracket to ensure no interference with the shutter system when moving.

Step 21: Alignment check

Check the alignment of the light assembly with the grill. Loosen the Phillips head screws to fix the alignment as needed.



Step 22: Harness prep

Secure both harnesses to the battery terminals. Loosely secure them around the vehicle battery. Run the switch lead along the firewall towards the driver side. Run the three connector leads towards the front of the vehicle and underneath the air intake. **DO NOT RECONNECT THE VEHICLE BATTERY.**

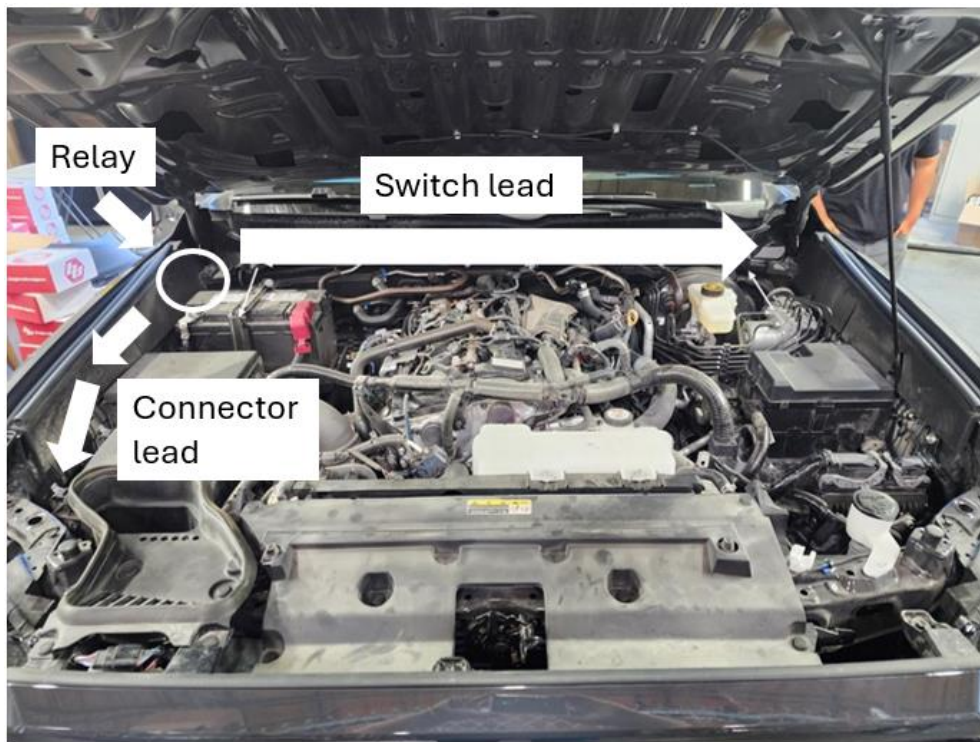



Step 23: Toggle Version ONLY (Skip to step 30 for upfitter version)

Disconnect the white connector on the switch lead and remove the connector from the switch side leaving the pins exposed.



Step 24: Firewall passthrough

Make a small hole in the firewall passthrough and pass the switch lead connector through the boot into the engine bay (pin side first). Wire emerges below the brake booster (driver side).



Step 25: Harness reconnection

Pull the switch lead into the engine bay until it is long enough to be reconnected to the original harness. Re-install the white connector onto the exposed pins using the format below and then reconnect the two harnesses.

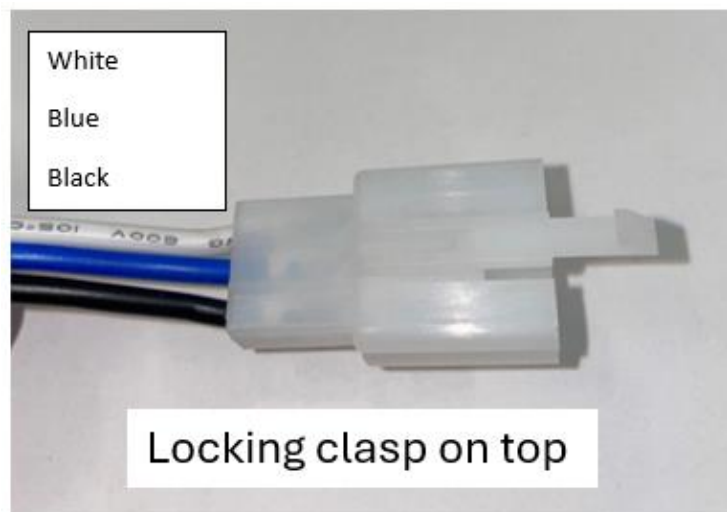

Step 26: Trim panel removal

Remove the door seal on the driver's side and the round trim panel pictured below.



Step 27: Trim panel removal

Remove the trim panel off the side of the dashboard by starting at the top edge and gently pulling away from the dash.

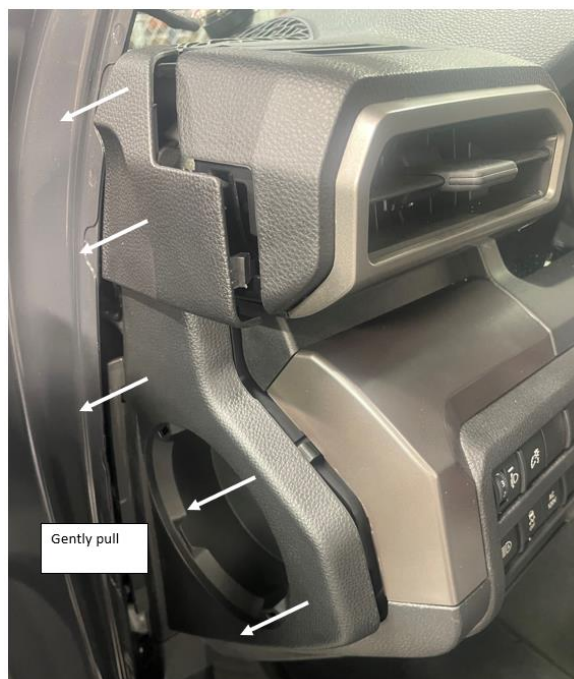

Step 28: Trim panel removed

Remove the chrome trim panel by pulling parallel to the arrows pictured.

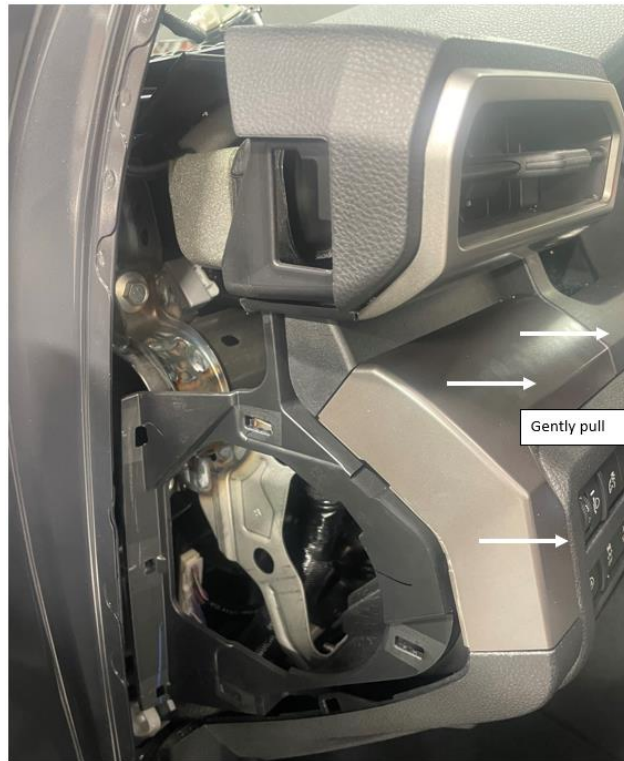

Step 29: Button Installation

Drill a hole .75" in diameter at the location specified. Remove the button from the switch harness leaving only the exposed pins. Run the harness up from the footwell behind the dash and into the newly made hole.

Re-install the button onto the harness and place it into the dashboard. Re-install all trim panels.

For this installation, check the clearance behind the panel and add an additional hole for the other switch.



BD Lighted Rocker

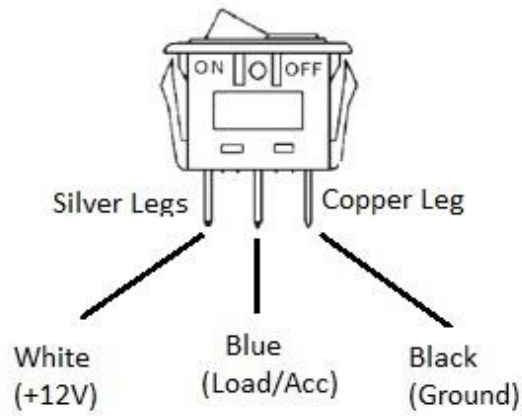

Skip to step 32 for final installation steps

Step 30: Upfitter Kits ONLY

Remove the OEM connector plug A from the harness behind the driver side headlight.

Location of auxiliary switch wire harness connectors:

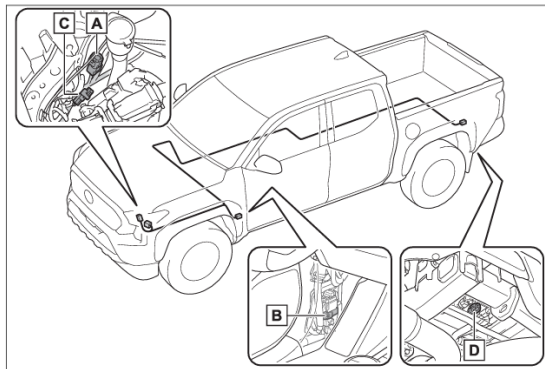

- A** Engine compartment
- B** Cabin (behind trim panel)
- C** Engine compartment
- D** Rear frame

Powered Circuits:

Circuit	Fuse Name	Fuse Size	Fuse Location	Pigtail Wire Color	Connector Location
AUX1	AUX NO.1	15A	Engine compartment	Black	Engine compartment A , cabin B
AUX2	AUX NO.2	10A		Green	
AUX3	AUX NO.3	5A		White	

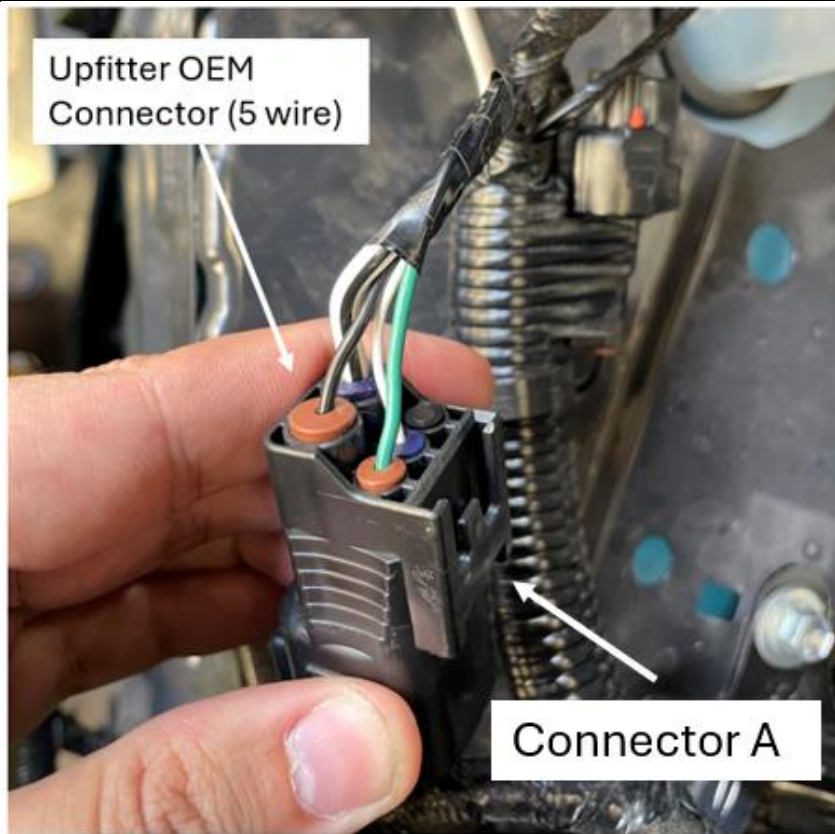

Step 31: Upfitter harness routing

Plug in the provided adapter and run the harness to the end of the toggle harness in step 23. Connect the two harnesses using the appropriate connector from the chart below. Tie away any slack using the zip ties provided.

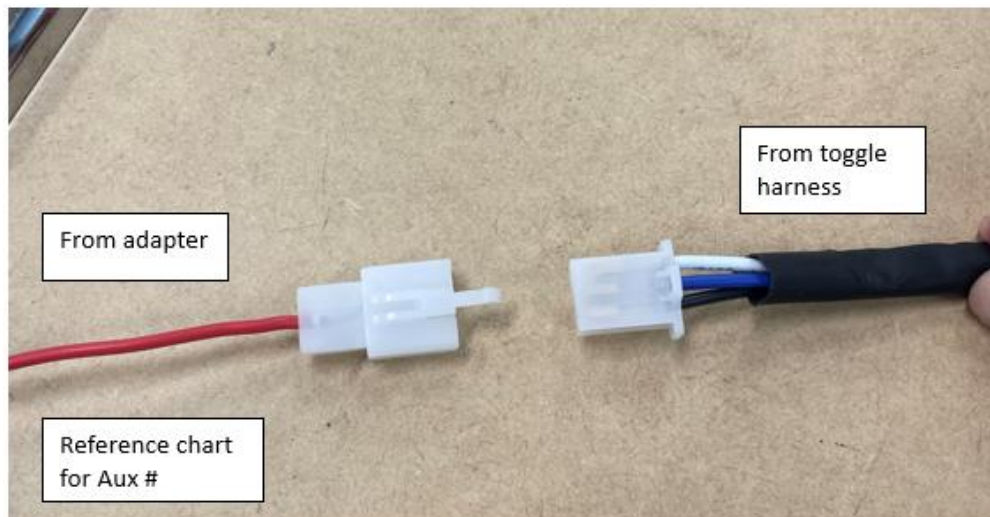

Depending on which Auxiliary (Aux) button you want to control your lights follow the reference below:

Aux 1: Connect your harness to red wire (Baja Designs adapter) (Pictured above)

Aux 2: Connect your harness to yellow wire (Baja Designs adapter)

Aux 3: Connect your harness to white wire (Baja Designs adapter)

Step 32: Install S8 Backlight

Take the additional backlight harness provided and swap the splice connector to the appropriate fuse tap provided.



Step 33: Backlight use only

1. Open the driver side fuse box located near the ABS pump (circled). Find the ignition pin shown in photo 1. (On the fuse map it is a 10-amp fuse labeled IGN.)



2. Remove the 10-amp fuse and insert the fuse tap into the slot. Insert the 10-amp fuse in the open spot in the fuse tap. Run the wires out of the fuse box and replace the cover.

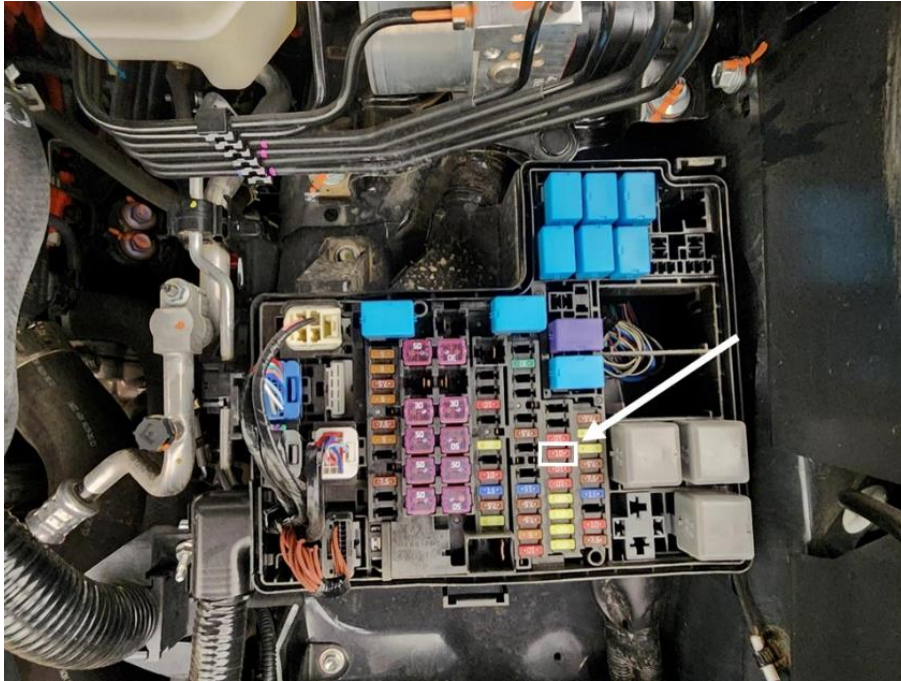

Step 34: Backlight harness routing

Run the harness to the front of the vehicle and install it into the 3-pin weather pack as seen below.

The connector is labeled with A-B-C

The pinout is as follows:

- A- Black/Ground
- B- White/ Power
- C- Green (S8 Light Bar Only)

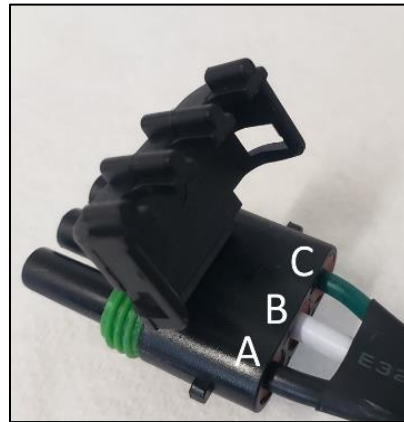

Step 35: Connecting to lights

Connect your harness to the light power cords. Secure the harness as tight to the bracket as possible to clear the shutter system.



Parts shown are preproduction parts and do not represent actual production

Step 36: Reinstall all vehicle body panels

Reinstall the shutter system and make sure the power cords/harness does not interfere with the shutter system. Reinstall the grill loosely and proceed to testing.

Step 37: Testing

Re-connect the 5X connectors from step 12. Re-connect the battery. Test the light functionality for S8 and S2's independently as well as the backlight feature (comes on with vehicle ignition).

Step 38: Complete reinstall

Fully clip the grill in place. Install all fasteners. Complete steps 7-14 in reverse.

Step 39: Installation complete!

*Tie all wires away from sharp, hot, and/or rotating components.

* Re-torque all the fasteners after 100 miles.

*Your install is now complete! Thank you for choosing Baja Designs.